

TWO-TRAY FINISHER
(Machine Code: B599)

1. REPLACEMENT AND ADJUSTMENT

1.1 COVERS

1.1.1 EXTERNAL COVERS

1. Top cover [A] (⚙ x 4)
NOTE: If the shift tray below is blocking the screw hole, remove the shift tray.
2. Bracket [B] (⚙ x 1)
3. Front door [C]
4. Rear cover [D] (⚙ x 4)
5. Right cover [E] (⚙ x 2)

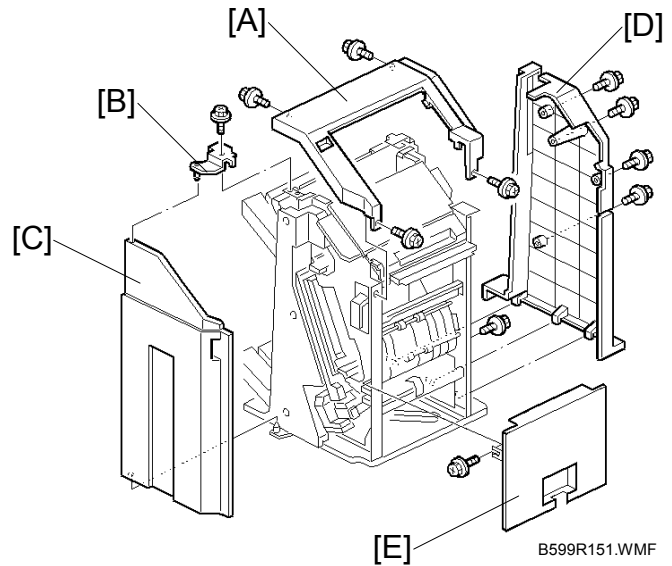

1.1.2 INNER COVER

1. Front cover (➔ 1.1.1 EXTERNAL COVERS)
2. Inner cover [A] (⚙ x 3, tabs [B] x 3)

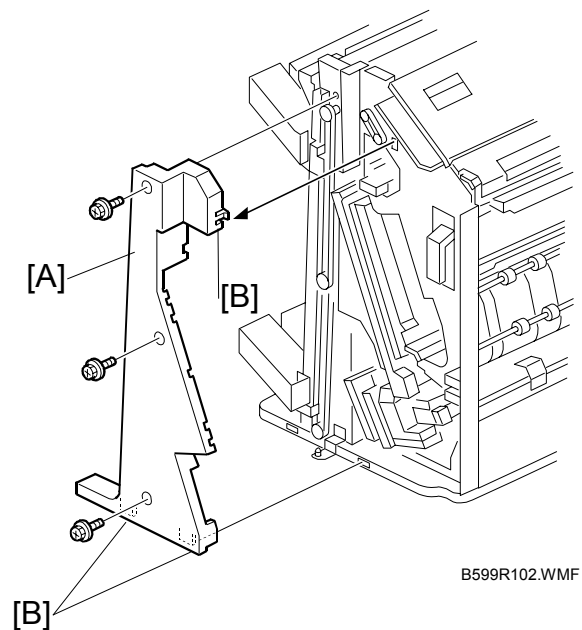

1.2 POSITIONING ROLLER

1. Open the front door.
2. Positioning roller [A] (🔧 x 1)
3. Belt [B]

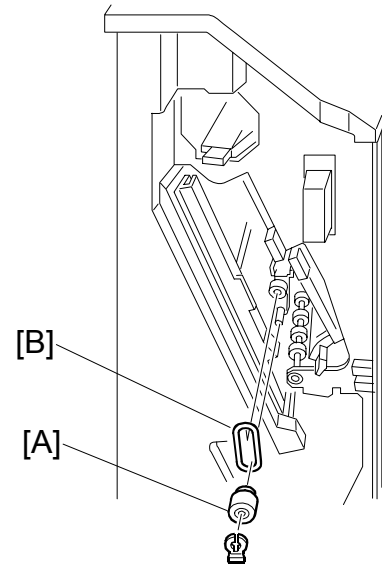

B599R103.WMF

1.3 TRAY 1 EXIT SENSOR

1. Top cover (➔ 1.1.1 EXTERNAL COVERS)
2. Open transport door [A]
3. Bracket [B] (🔧 x 1, 📏 x 1)
4. Tray 1 exit sensor [C]

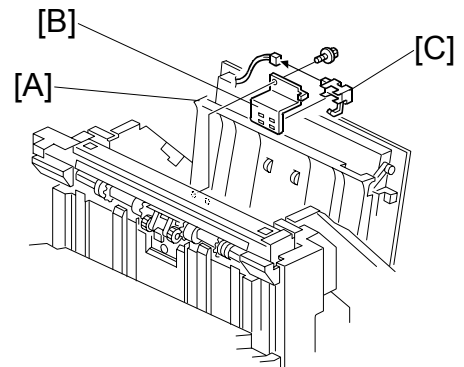

B599R104.WMF

1.4 ENTRANCE SENSOR/STAPLER TRAY ENTRANCE SENSOR

1. Entrance sensor bracket [A] (⚙ x 1, 📏 x 1)
2. Entrance sensor [B] (⚙ x 1)
3. Stapler tray entrance sensor bracket [C] (⚙ x 1, 📏 x 1)
4. Stapler tray entrance sensor [D]

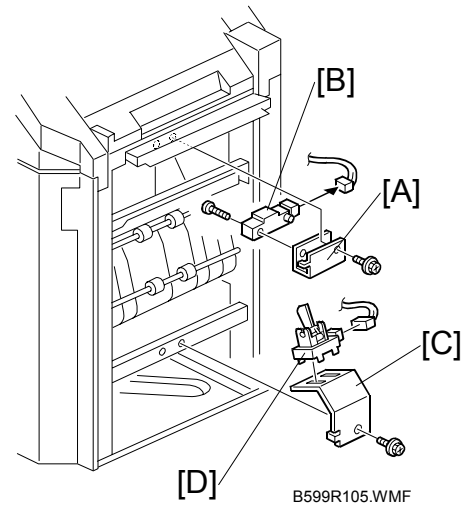

1.5 STAPLER TRAY

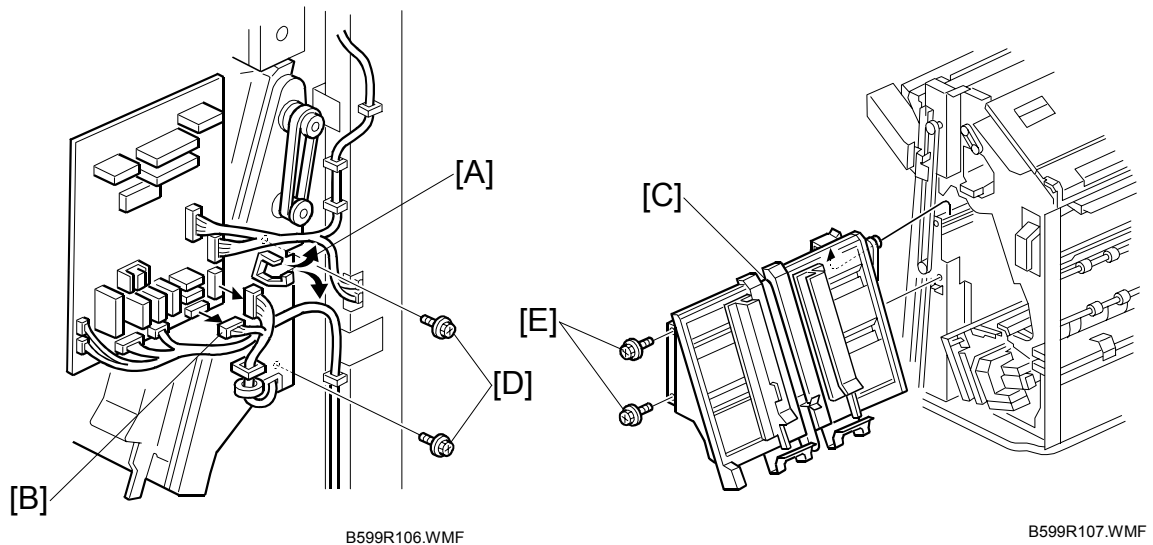

1. External covers, front door, inner cover (☛ 1.1.1 EXTERNAL COVERS, 1.1.2 INNER COVER)
2. Two clamps [A]
3. Harnesses [B] (📏 x 8)
4. Stapler tray [C] (⚙ x 2 [D], ⚙ x 2 [E])

NOTE: At the front of the finisher, pull the stapler tray toward you and lift it out.

1.6 UPPER STACK HEIGHT SENSORS/TRAY 1 UPPER LIMIT SWITCH

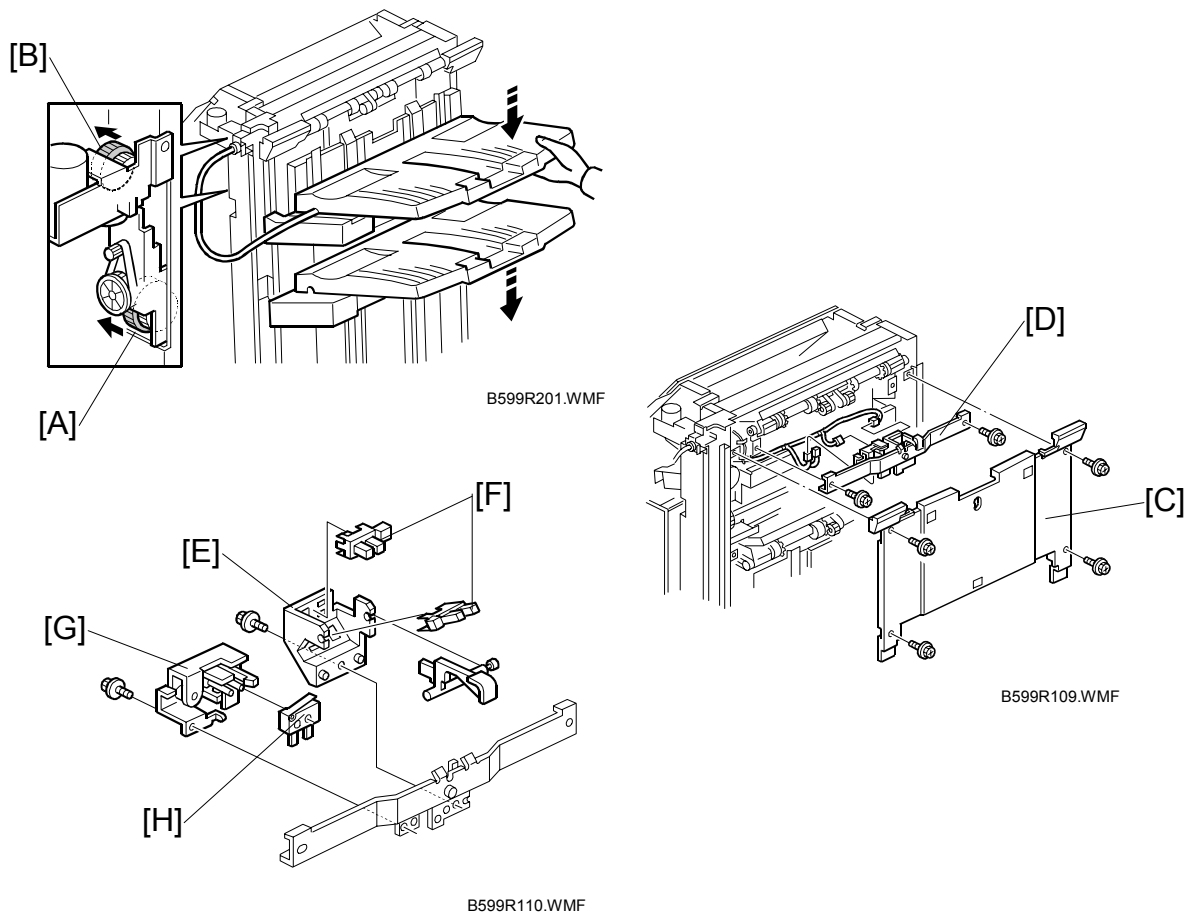

1. External covers (☛ 1.1.1)
2. Place one hand under tray 2 (the lower tray), press in on the gear [A] to release the tray, and then support it with your hand as it descends.
3. Place one hand under tray 1 (the upper tray), press in on the gear [B] to release the tray, and then support it with your hand as it descends.
4. Tray 1 back fence [C] (☛ x 4)
5. Sensor stay [D] (☛ x 2, (☛) x 4)
6. Plastic bracket [E] (☛ x 1)
7. Stack height sensors [F]
8. Metal bracket [G] (☛ x 1)
9. Upper limit switch [H]

1.7 EXIT GUIDE PLATE MOTOR

1. Tray 1 back fence (☛ 1.6)
2. Exit guide plate motor [A] (🔩 x2, 📡 x1)

NOTE: Disengage the shaft of the exit guide plate motor from the ring.

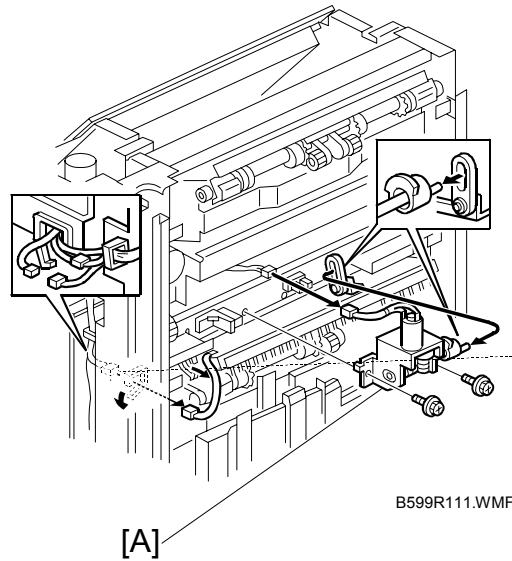

1.8 LIFT MOTORS

1. Top cover and rear cover (☛ 1.1.1)
2. Tray 1 back fence [A] (☛ 1.6)
3. Sensor stay [B] (🔩 x 4)

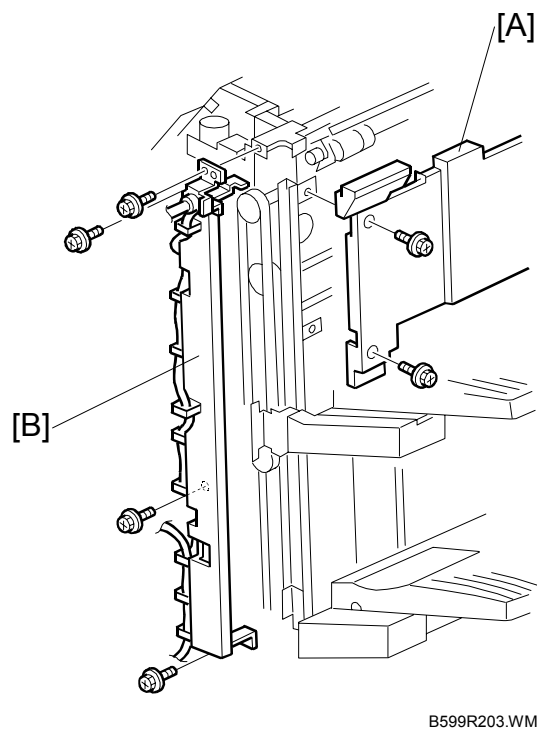

Peripherals

- 4. Motor bracket [C] (⚙️ x 3, ⚙️ x 2)

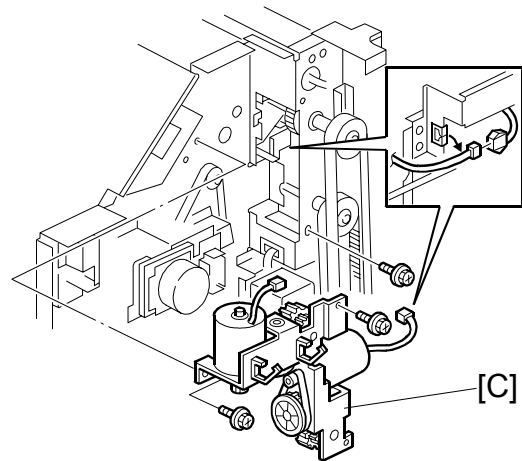

B599R204.WMF

- 5. Tray 1 lift motor [D] (⚙️ x 2, drive belt)
- 6. Tray 2 lift motor [E] (⚙️ x 2, drive belt)

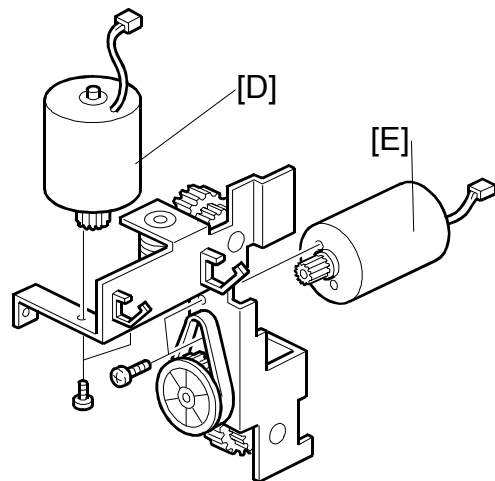

B599R205.WMF

1.9 LOWER EXIT SENSOR

1. Front door, external and internal covers. (☛ 1.1)
2. Exit guide plate motor (☛ 1.7)
3. Guide plate [A] (☛ x 1)
NOTE: Pull the shaft toward you through the round hole.

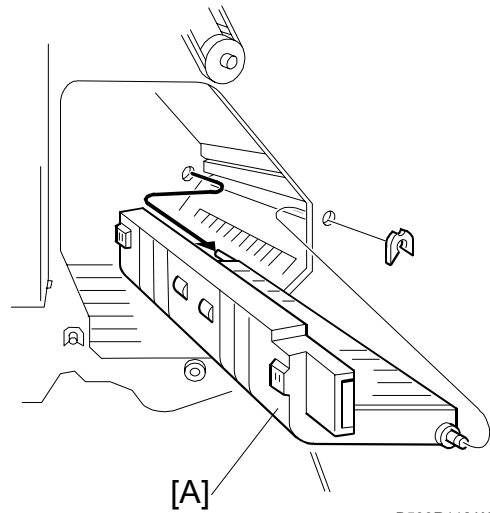

4. Guide plate exit assembly [B] (☛ x 1, ☛ x 1)

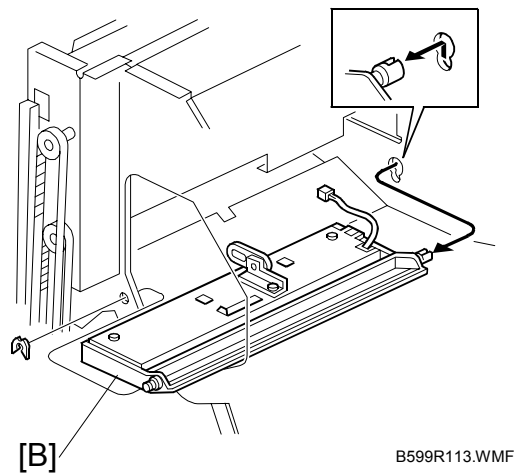

5. Anti-static brush [C] (☛ x 2)
6. Bracket guide exit [D] (☛ x 2)
7. Lower exit sensor [E] (☛ x 1, ☛ x 1)

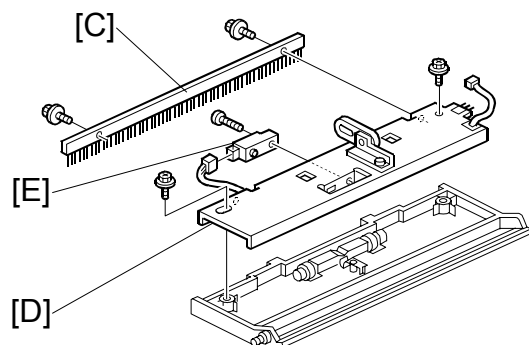

Peripherals

1.10 LOWER STACK HEIGHT SENSORS

1. Stapler tray (☛ 1.5)
2. Sensor bracket [A] (🔩 x 1, 📐 x 2)
3. Bracket [B] (🔩 x 1)
4. Feeler [C]
5. Lower stack height sensors [D]

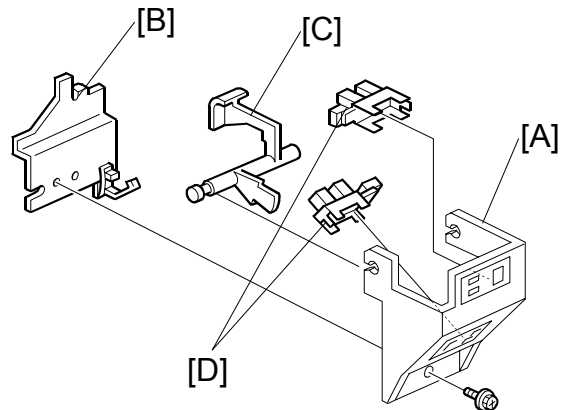

B599R116.WMF

1.11 TRAY 2 SHUNT POSITION SENSOR

1. Stapler tray (☛ 1.5)
2. Sensor bracket [A] (🔩 x 1, 📐 x 1)
3. Tray 2 shunt position sensor [B] (🔩 x 1)

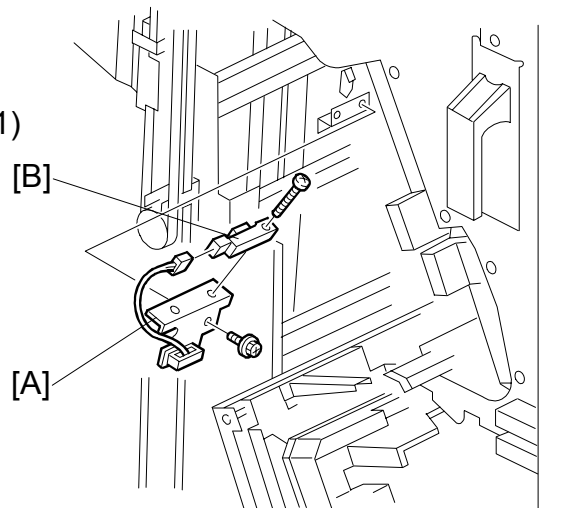

B599R202.WMF

1.12 STAPLER UNIT

1. Open the front door
 2. Stapler unit [A] (🔩 x 1, 📐 x 2)
- NOTE:** Hold the stapler holder [B] with one hand as you remove the stapler. Do not twist or rotate the stapler bracket as you remove it.

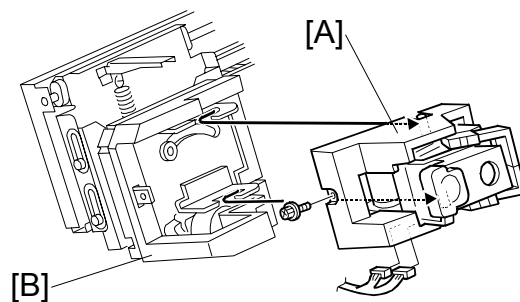

B599R117.WMF

1.13 STAPLER ROTATION HP SENSOR

1. Stapler unit (☛ 1.12)
2. Carefully rotate the stapler holder [A].
3. Stapler cover [B] (🔩 x 1)
4. Sensor bracket [C] (🔩 x 1, 📏 x 1)
5. Stapler rotation HP sensor [D]

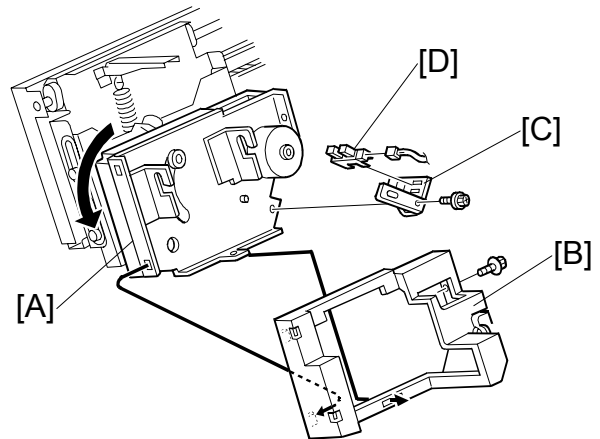

B599R118.WMF

1.14 TRAY 1 INTERIOR

1.14.1 TRAY 1 COVERS

1. Tray 1 [A] (🔩 x 1)
2. Rear tray cover [B] (🔩 x 1)
3. Front tray cover [C] (🔩 x 1)
4. Bottom tray cover [D] (🔩 x 2)

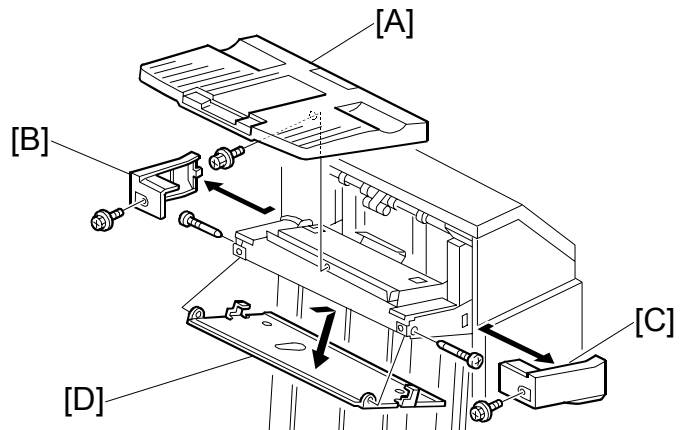

B599R207.WMF

5. Bottom bracket [E] (🔩 x 3)

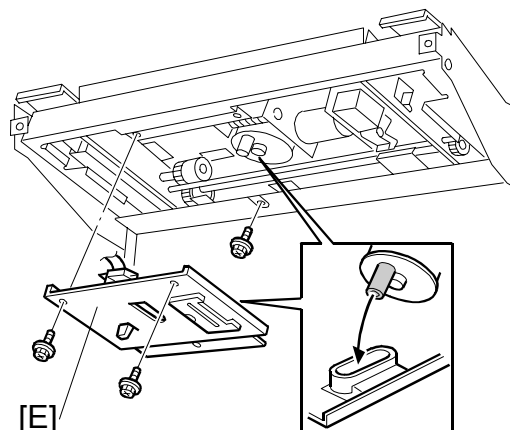

B599R208.WMF

1.14.2 TRAY SHIFT SENSORS AND TRAY RELEASE SENSOR

1. Tray 1 covers (☛ 1.14.1)
2. Gear disk [A] (☛ x 1)
3. Tray shift sensors [B] (☛ x 1 each).
4. Tray release sensor [C] (☛ x 1)

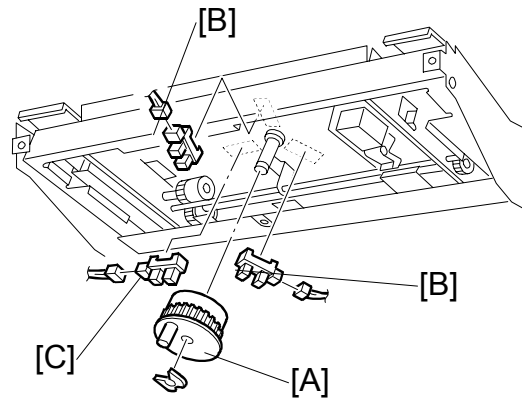

B599R210.WMF

1.14.3 TRAY 1 SHIFT MOTOR

1. Tray 1 covers (☛ 1.14.1)
2. Motor bracket [A] (☛ x 3, ☛ x 1)
3. Tray 1 shift motor [B] (☛ x 3, belt x 1)

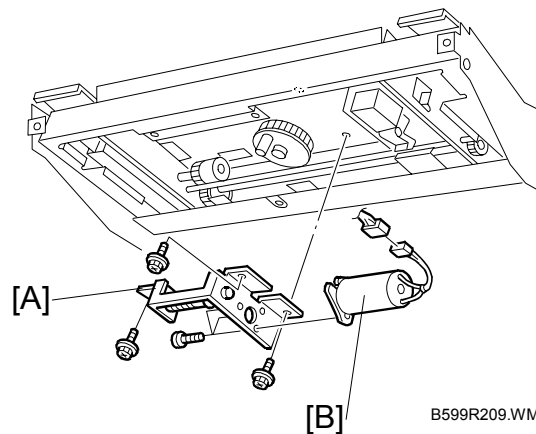

B599R209.WMF

1.14.4 BACK FENCE LOCK CLUTCH

1. Tray 1 covers (☛ 1.14.1)
2. Back fence lock clutch [A] (☛ x 1, ☛ x 1)

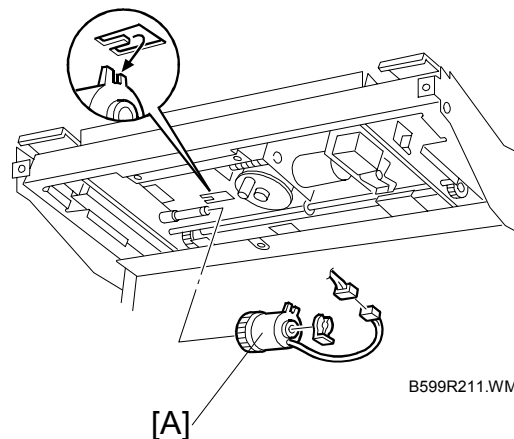

B599R211.WMF

1.15 FINISHER MAIN BOARD

1. Rear cover (☛ 1.1.1)
2. Main PCB [A] (☛ x 6, All ☛)

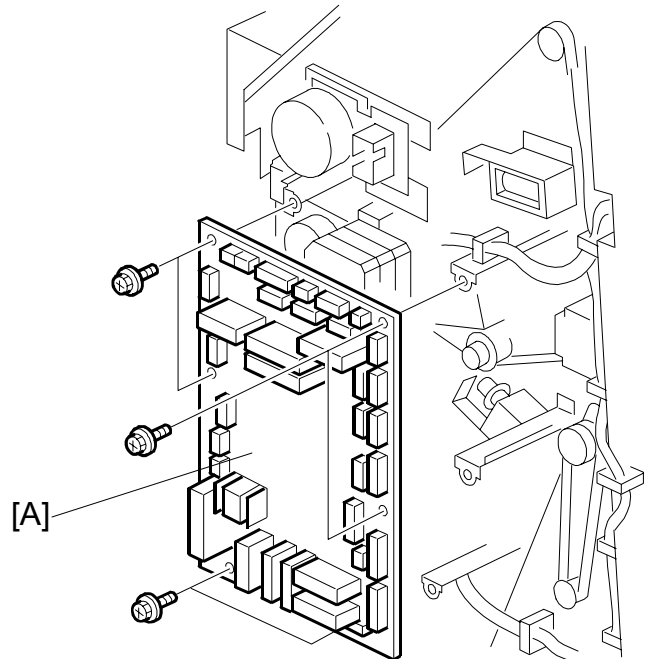

B599R206.WMF

1.16 PUNCH HOLE POSITION ADJUSTMENT

To adjust the position of the punch holes in the paper feed direction, use the appropriate SP mode.

To adjust the horizontal position of the holes, use the spacers provided with the punch unit.

1. Rear cover (☛ 1.1.1)
2. Punch unit [A] (☛ x 3, ☛ x 5)
3. Spacers [B]

The punch position can be adjusted by up to 4 mm using combinations of the 3 spacers provided with the finisher.

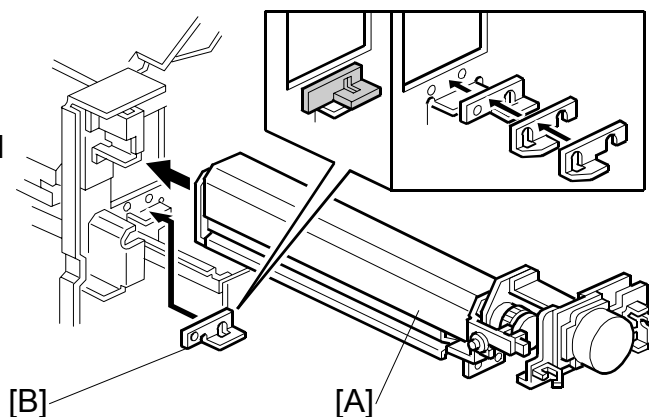

B599R119.WMF

2. TROUBLESHOOTING

2.1 JAM DETECTION

Mode			Jam	Content
Shift 1	Shift 2	Staple		
✓	✓	✓	Entrance sensor: no detection	After the exit sensor in the main machine went off, the entrance sensor did not switch on for at least 2 s.
✓	✓	✓	Entrance sensor: no detection	After the entrance sensor switched on, it did not remain on for at least 150 ms.* ¹
✓			Upper exit sensor: no detection	After the entrance sensor switched on, the upper exit sensor did not remain on for at least 59 pulses.* ²
✓			Upper exit sensor: jam	After the upper exit sensor switched on, it did not switch off within 150 ms.* ¹
	✓		Lower exit sensor: no detection	After the entrance sensor switched on, the lower exit sensor did not switch on within 59 pulses.* ²
	✓		Lower exit sensor: jam	After the lower exit sensor switched on, it did not switch off within 150 ms.* ¹
		✓	Stapler tray entrance sensor: no detection	After the entrance sensor switched off, the stapler tray entrance sensor did not switch on within 102 pulses.* ²
		✓	Stapler tray entrance sensor: jam	After the stapler tray entrance sensor switched on, it did not switch off within 59 pulses.* ¹
		✓	Lower tray exit sensor: no detection	After the transport motor switched on, the lower tray exit sensor did not switch on within 1260 ms.

*¹: Timing for A4 L (differs according to paper size).

*²: Counted by entrance motor pulses because timing differs for feed out.

3. SERVICE TABLES

3.1 DIP SWITCH SETTINGS

The DIP switches should not be set to any combination other than those described in the table below.

DPS101				Mode	Description
1	2	3	4		
0	0	0	0	Default.	
1	1	1	0	Free run.	No paper.
0	0	0	1	Transportation	See the note below.

NOTE: The following procedure repositions the shift trays to the shipping position.

- 1) Make sure that the main switch is turned off.
- 2) Turn on DIP SW101-4 on the main board.
- 3) Turn on the main switch.
- 4) After the fisher completes the initialization, turn off DIP SW101-4.
Finisher automatically repositions the shift trays to the shipping position.

3.2 TEST POINTS

No.	Label	Monitored Signal
TP101	GND	Ground
TP102	5 V	5 V
TP103	RXD	Received command data
TP104	TXD	Transmitted command data

3.3 FUSES

No.	Function
FU101	Protects 24 V.

4. DETAILED DESCRIPTIONS

4.1 GENERAL LAYOUT

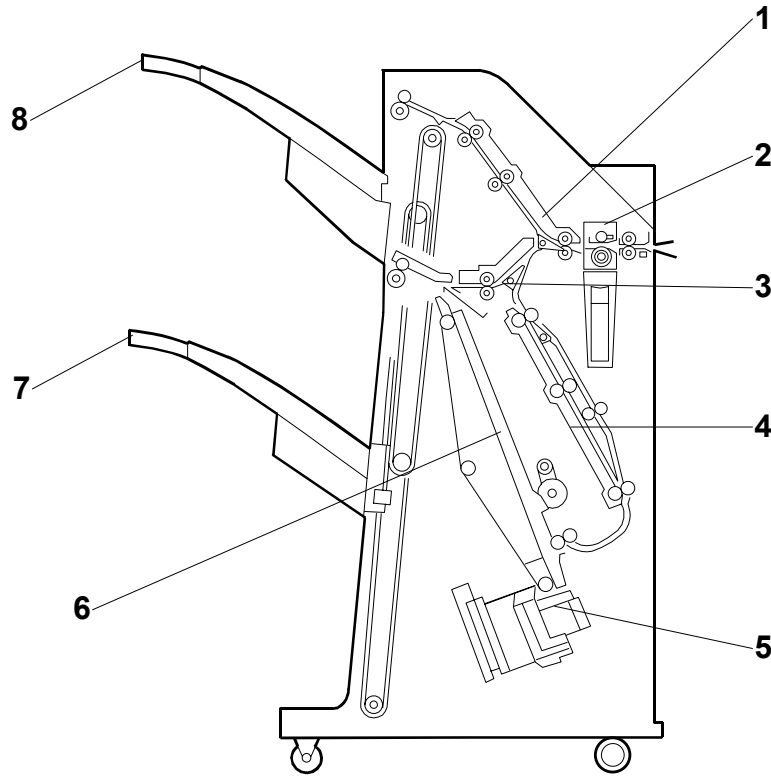

B599D118.WMF

- | | |
|--------------------------|-----------------|
| 1. Upper junction gate | 5. Stapler |
| 2. Punch unit (option) | 6. Stapler tray |
| 3. Stapler junction gate | 7. Tray 2 |
| 4. Pre-stack tray | 8. Tray 1 |

Tray junction gate: Directs paper either to the upper or lower exit. In staple mode, the stack always goes out to the lower exit.

Stapler junction gate: Directs paper either to the lower exit or to the stapler tray.

Pre-stack tray: When stapling multiple prints (A4 LEF, LT LEF, B5 LEF only) in the staple mode, the first sheet of the second print waits here for the next sheet to feed while the previous stack is stapled. After the second print is fed, the first and second sheets are fed together to the pre-stack tray. This delay allows enough time for the previous stack to be stapled without interrupting paper feed.

Shift trays: Tray 1 (upper) and tray 2 (lower) shift side to side in the sort mode, and raise and lower to receive ejected prints.

Stapler tray jogger: Employs positioning rollers and jogger fences to align stacks for stapling.

Punch unit: Punches holes in stacked prints.

4.2 DRIVE LAYOUT

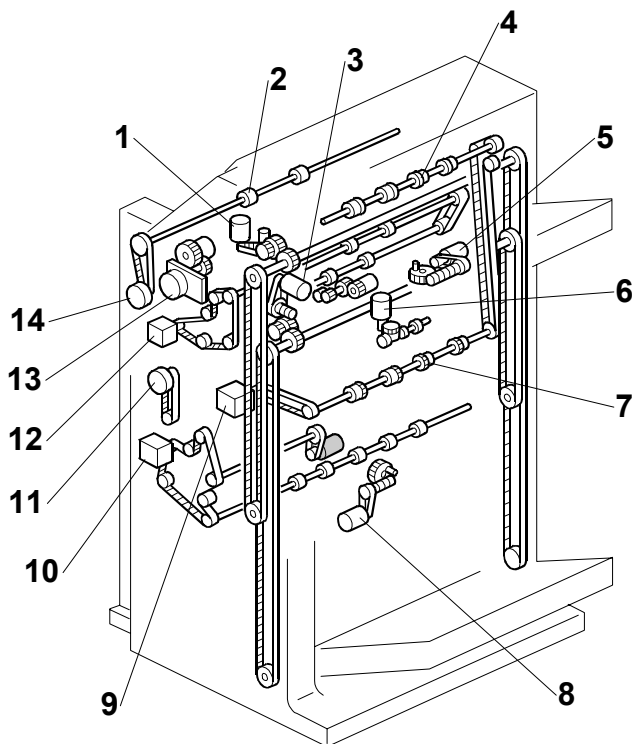

B599D104.WMF

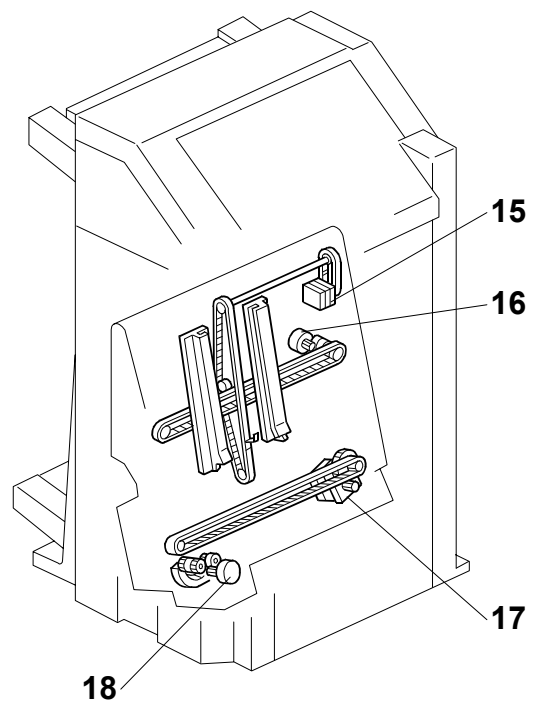

B599D103.WMF

- | | |
|---------------------------|----------------------------|
| 1. Tray 1 lift motor | 10. Lower transport motor |
| 2. Entrance roller | 11. Pre-stack motor |
| 3. Tray 2 lift motor | 12. Upper transport motor |
| 4. Upper exit roller | 13. Punch motor |
| 5. Tray 1 shift motor | 14. Entrance motor |
| 6. Exit guide plate motor | 15. Stack feed-out motor |
| 7. Lower exit roller | 16. Jogger motor |
| 8. Tray 2 shift motor | 17. Stapler motor |
| 9. Exit motor | 18. Stapler rotation motor |

4.3 JUNCTION GATES

The two junction gates can direct paper to three destinations.

In sort/stack mode for tray 1, the tray junction solenoid [A] is on, and the prints go to the upper exit (tray 1 is at the upper exit for sort/stack mode).

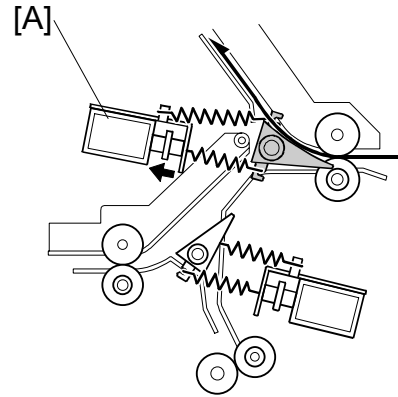

In sort/stack mode for tray 2, both the tray junction gate solenoid [A] and stapler junction gate solenoid [B] are off, and prints go to the lower exit.

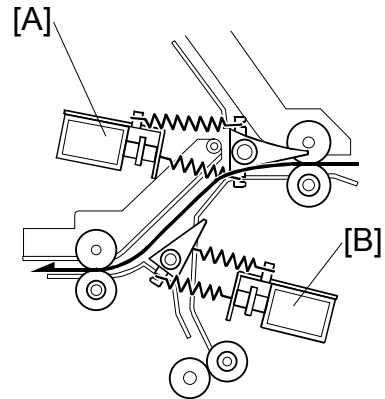

In staple mode, the tray junction solenoid [A] is off and the stapler junction gate solenoid [B] is on, and prints go to the stapler tray.

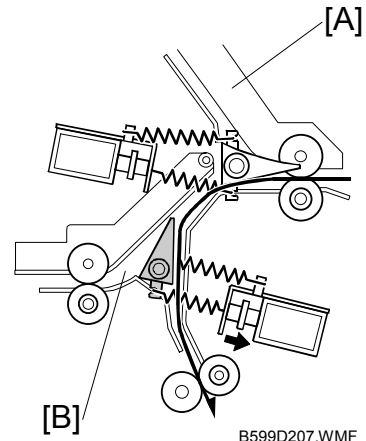

4.4 TRAY SHIFTING

4.4.1 TRAY SHIFT MECHANISMS

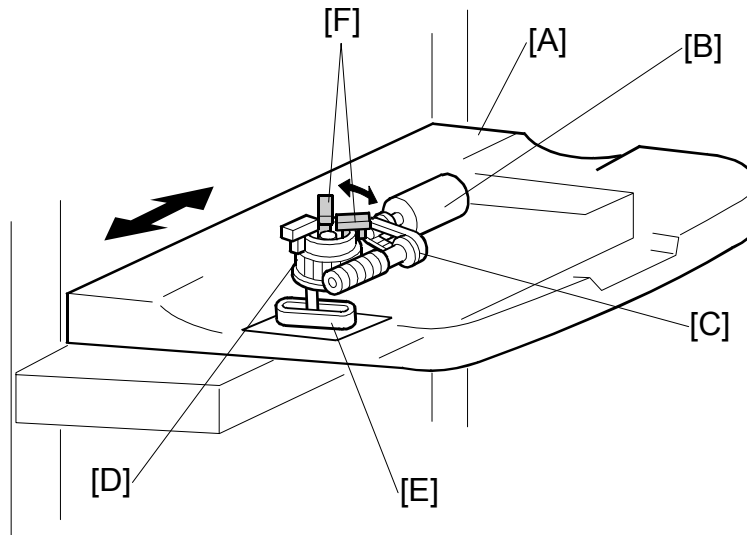

B599D106.WMF

Tray 1 (Upper Tray)

In sort/stack mode, tray 1 [A] moves from side to side to separate the printed sets.

The tray 1 shift motor [B], inside the shift tray, controls the horizontal position of tray 1 through the timing belt [C] and gear disk [D].

After one print set is delivered to tray 1, the shift motor turns on, driving the gear disk and the arm [E], and the tray drive unit moves to one side.

Two shift sensors [F] detect when to stop this side-to-side movement. There is a cut-out in the gear disk. The shift tray moves in one direction until one of the shift sensors detects the cut-out. Then the shift tray stops.

The next set of prints is then delivered, and the gear disk is turned in the opposite direction until the other shift sensor is activated.

Tray 2 (Lower Tray)

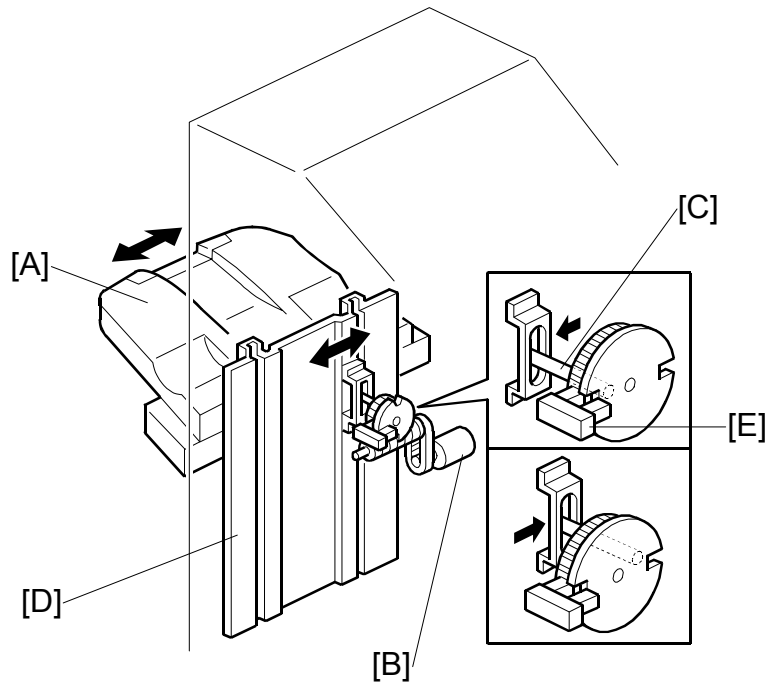

B599D105.WMF

In sort/stack mode, tray 2 [A] moves from side to side to separate the sets of prints. The shift mechanism for tray 2 is similar to that used for tray 1. However, when the tray 2 shift motor [B] turns on, the arm [D] moves the entire end fence [C] from side to side (not just the tray).

After the gear disk has turned 180 degrees, the cut-out in the gear disk enters the tray half-turn sensor [E], and the motor stops. When the next set of prints is delivered, the motor turns on again, and moves the tray back to its previous position.

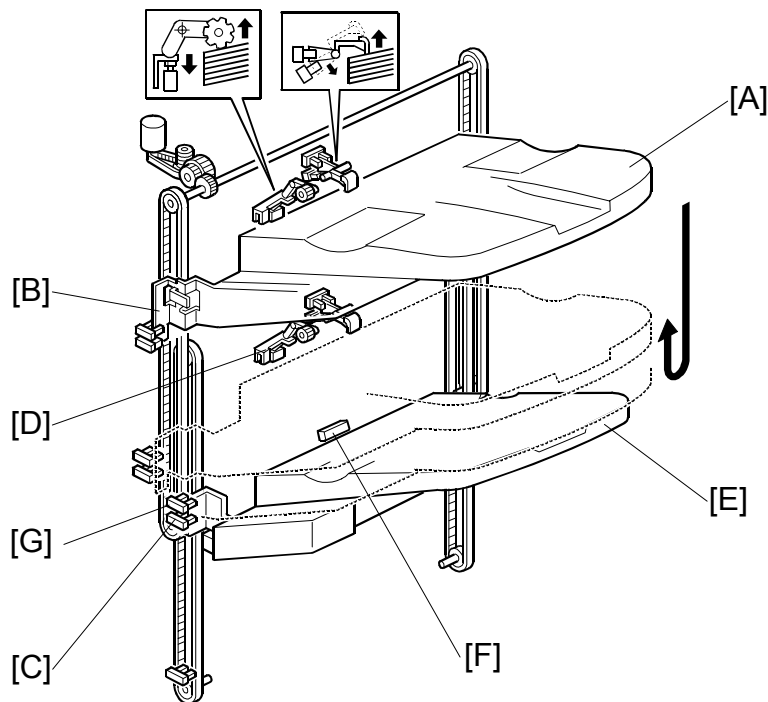
Staple Mode

B599D204.WMF

In staple mode, stapled stacks can be delivered to either tray, but they can only go to the lower exit. So, if tray 1 is selected, tray 1 [A] moves down to the lower paper exit.

Tray 1 lowers until the actuator [B] enters the tray 1 lower limit sensor [C]. Tray 1 then lifts up until lower stack height sensor 1 [D] is activated.

When tray 1 is moved down to the lower exit, tray 2 must be moved down out of the way. So, tray 2 [E] is also lowered until the tray 2 shunt position sensor [F] detects tray 2 (or the top of the paper stack in tray 2).

The method of paper height detection is the same as for the upper exit area.

When the tray lowers during printing, the actuator will enter the tray 1 overflow 2 sensor [G]. When this happens, the machine detects that the paper stack height has exceeded the overflow limit.

Tray 1 release mechanism

When tray 1 is selected for staple mode, tray 1 must be moved down to the lower paper exit. However, to move past the sensors at the lower exit, the tray must be moved away from the finisher.

To do this, the tray 1 shift motor turns until the cut-out in the gear disk enters the tray release sensor [A]. At this time, the arm [B] has reached position [C], and is pushing against the plate [D], in towards the finisher. However, the plate is fixed, so the tray moves out away from the finisher.

Then, the tray 1 shift motor stops, then the tray 1 lift motor lowers tray 1.

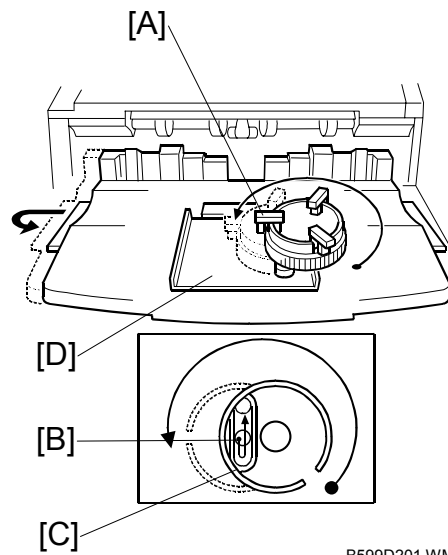

When the tray 1 lower limit sensor is activated (as described on the previous page), the tray has moved past the sensors at the lower exit. The tray 1 shift motor turns on again until the gear disk activates the tray shift sensor [E]. This moves the tray back against the finisher.

Next, tray 1 lifts until the finisher detects that the tray is at the correct height.

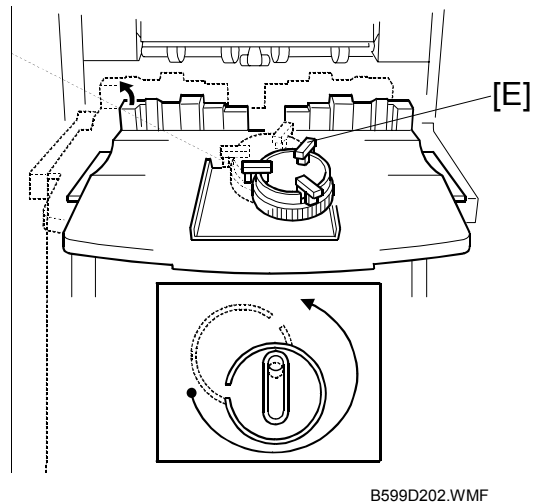

When tray 1 is at the lower exit, the tray lock solenoid [F] is on, and the lever [G] locks the tray. This prevents the user from moving the tray out of position (the first tray has some play when it is at the lower position).

Before tray 1 goes back to the upper exit area, the tray lock solenoid [F] turns off to unlock the tray. In addition, the back fence lock clutch [H] turns on to hold the back fence [I]. This prevents the springs inside the back fence from suddenly contracting (these springs normally keep the tray steady during side-to-side shift).

Then, tray 1 is released and it moves up to the upper exit area.

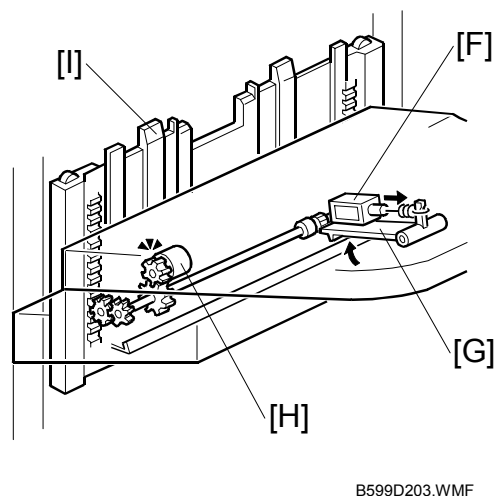

Peripherals

4.5.2 TRAY 2

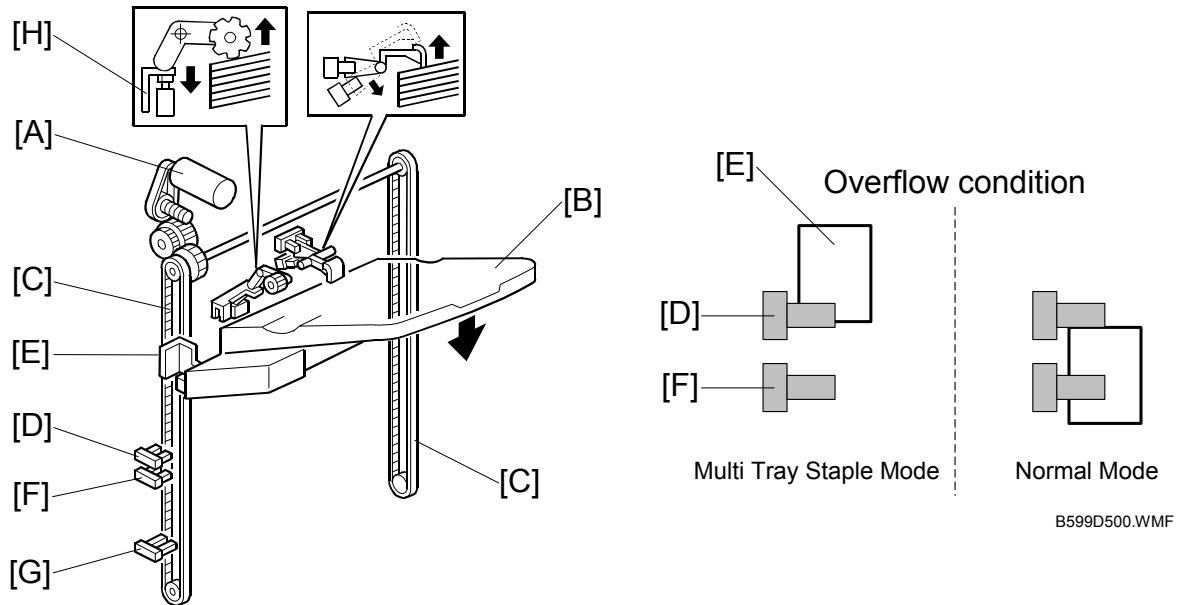

B599D109.WMF

The tray 2 lift motor [A] controls the vertical position of tray 2 [B] through gears and timing belts [C].

The paper height detection is the same as for tray 1.

When the tray lowers during printing, the tray is judged to be overflowing when the tray 2 overflow sensor 1 [D] is off and the tray 2 overflow sensor-2 [F] is on (see 'Normal Mode' in the above diagram).

In the multi-tray staple mode (selected by the service technician), the machine detects that the paper stack height has exceeded the overflow limit when the actuator [E] enters the tray 2 overflow 1 sensor [D].

The lower limit sensor [G] for tray 2 detects when tray 2 is at its lowest limit and stops the tray 2 lift motor.

The function of the tray 2 upper limit switch [H] is the same as for tray 1.

4.5.3 PRE-STACK MECHANISM

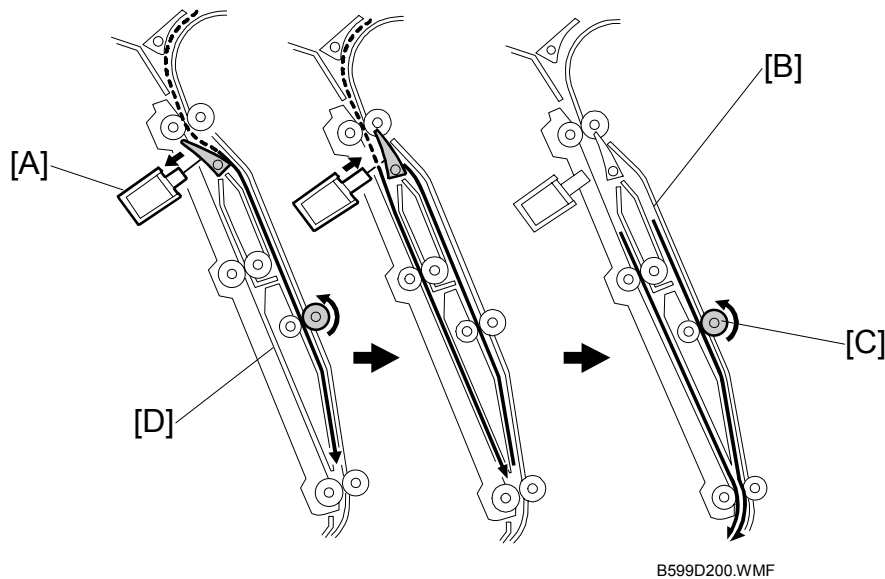

NOTE: This feature is available only when using A4 L, LT L, and B5 L.

During stapling, the main machine must wait. This mechanism reduces the wait by holding the first two sheets of a job while the previous job is still being stapled. It only works during the second and subsequent sets of a multi-set print job.

The pre-stack junction gate solenoid [A] switches on after the first sheet activates the entrance sensor. This directs the sheet to the pre-stack tray [B].

The pre-stack feed roller [C] stops for a specified time after the trailing edge of the paper has passed through the entrance sensor and stops the paper from leaving the pre-stack tray.

At the same time, the pre-stack junction gate solenoid switches off, and the second sheet is sent to the paper guide [D]. The pre-stack feed roller (controlled by the pre-stack motor) starts to rotate again for a specified time after the trailing edge of the second page has been passed through the entrance sensor, and then both sheets are sent to the stapler tray together.

4.6 JOGGER UNIT PAPER POSITIONING MECHANISM

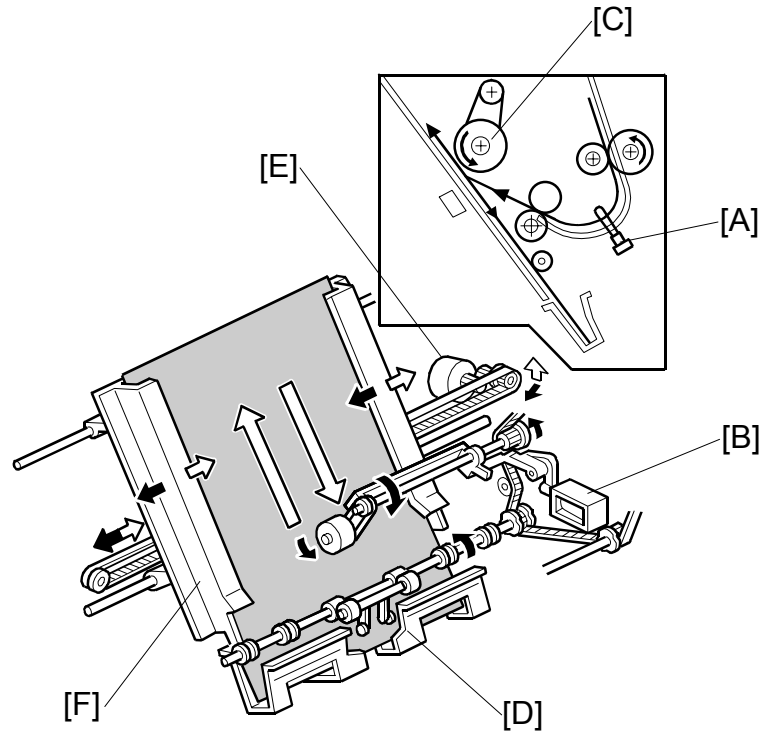

B599D110.WMF

In staple mode, each sheet of print paper is vertically and horizontally aligned when it arrives in the stapler tray.

Vertical Paper Alignment

After the trailing edge of the paper passes the stapler tray entrance sensor [A], the positioning roller solenoid [B] is energized for a specified time to push the positioning roller [C] into contact with the paper.

The positioning roller rotates to push the paper back and align the trailing edge of the paper against the stack stopper [D].

Horizontal Paper Alignment

When the start key is pressed, the jogger motor [E] turns on and the jogger fences [F] move to the waiting position, which is 8 mm wider on both sides than the selected paper.

When the trailing edge of the paper passes the stapler tray entrance sensor, the jogger motor turns on to move the jogger fences 5 mm towards the paper. After a short time, the jogger motor turns on again for the horizontal paper alignment then returns to the waiting position.

4.7 STAPLER MECHANISM

4.7.1 STAPLER MOVEMENT

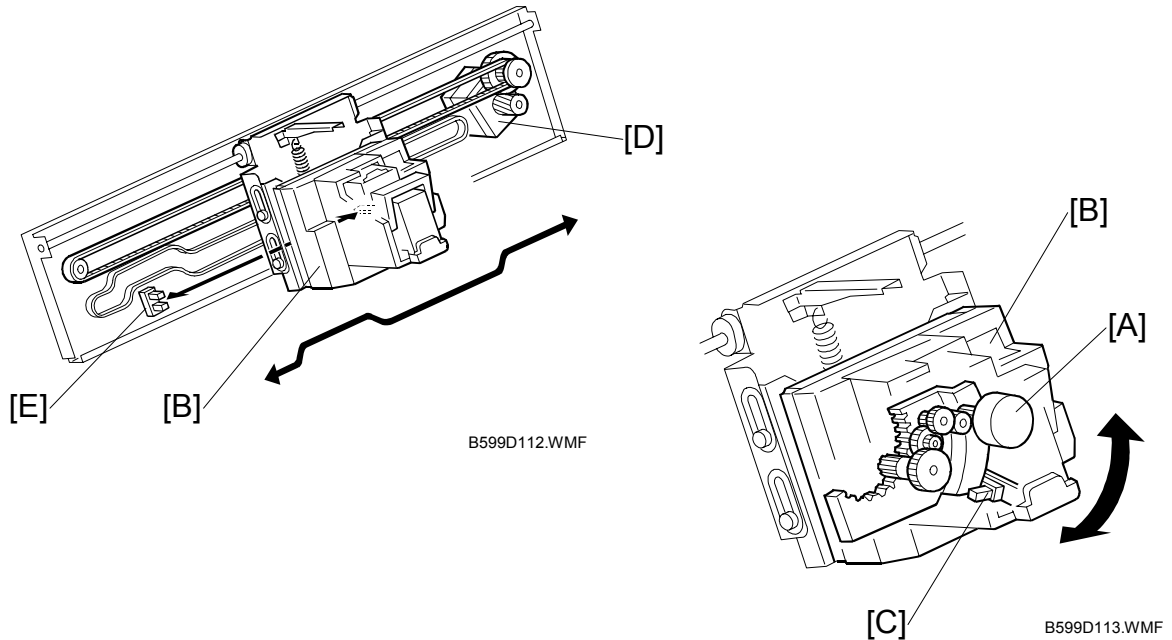

The stapler can be moved from side to side or rotated according to the requirements of the selected stapling mode.

Stapler Rotation

After the start key is pressed, the stapler rotation motor [A] rotates the staple unit [B] until the stapler rotation HP sensor [C] is activated. Then, the stapler moves from front to rear of the finisher.

When oblique stapling at one position has been selected, after the stapler moves to the stapling position, the stapler rotation motor rotates the stapler 45 degrees (clockwise) at the stapling position before the stapler fires.

Side-to-Side Movement

The stapler motor [D] moves the stapler from side to side. After the start key is pressed, the stapler moves from its home position to the stapling position.

The amount of movement required to reach the stapling position is determined by the size of the selected paper. If the two-staple mode is selected, the stapler moves to the front stapling position first, and then moves to the rear stapling position. However, for the next print set, it staples in the reverse order.

After the stapling job is finished, the stapler returns to its home position, determined by the stapler HP sensor [E].

4.7.2 STAPLER

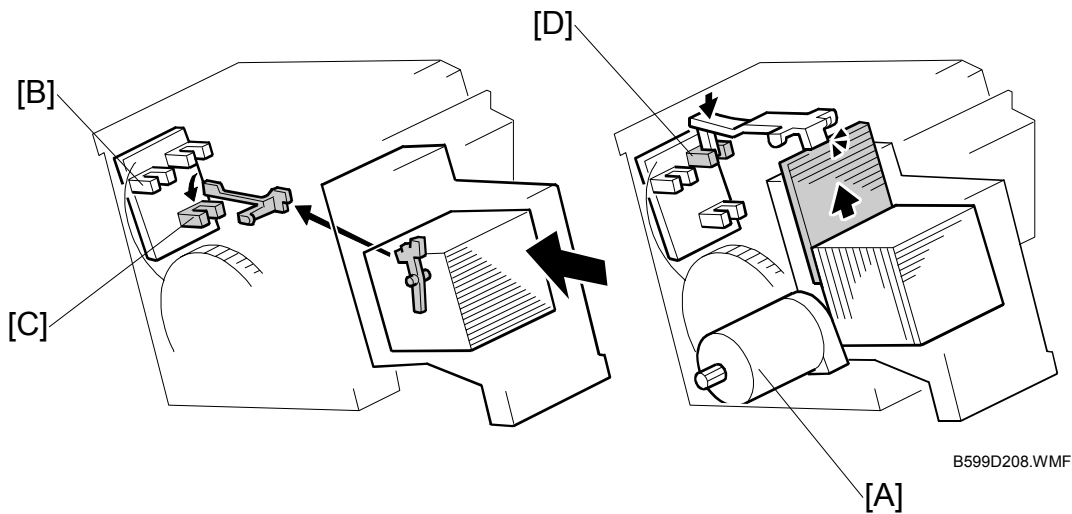

The staple hammer is driven by the stapler hammer motor [A] inside the stapler.

As soon as the paper stack is aligned, the staple hammer motor starts. When stapling is finished, the staple hammer HP sensor [B] is turned on, and the staple hammer motor then stops.

The staple end sensor [C] detects the staple end condition and whether the staple cartridge is installed or not. If a stapler cassette is not installed, or after the stapler cassette runs out of staples, a message is displayed in the operation panel. If this condition is detected during a print job, the indicator will appear, but the print job will not stop.

The staple position sensor [D] detects if there is a staple sheet at the stapling position. After a new staple cartridge is installed, the staple hammer motor turns on to transfer the staple sheet until the staple position sensor is activated by the staple sheet.

If a staple jam occurs and overloads the motor, this causes a staple jam message to appear on the operation panel.

4.7.3 FEED OUT AND TRANSPORT

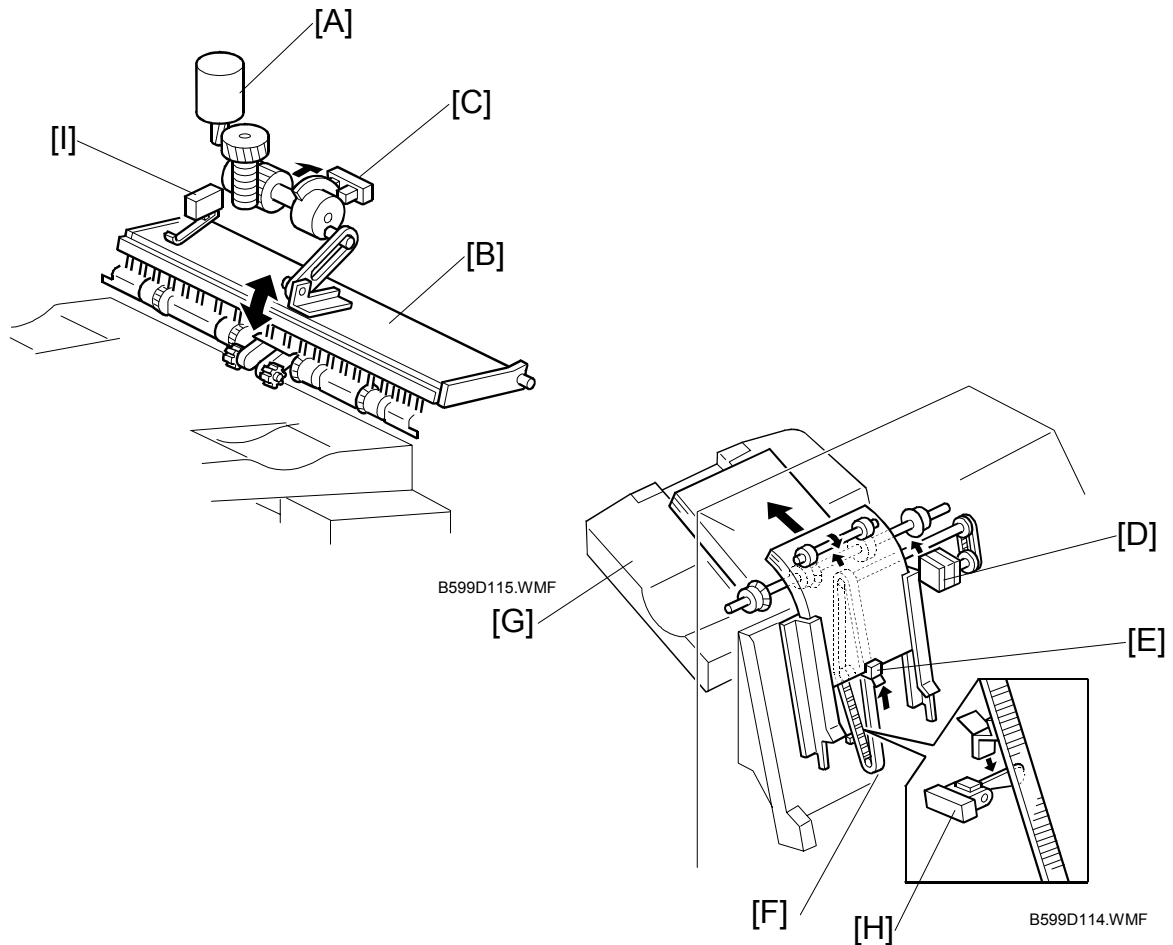

When stapling starts, the exit guide plate motor [A] switches on and opens the exit guide plate [B], so that the stapled stack can exit to the tray. The exit guide plate sensor [C] detects when to switch off the exit guide plate motor.

After the prints have been stapled, the stack feed-out motor [D] starts. The pawl [E] on the stack feed out belt [F] lifts the stapled set and feeds it to the tray [G].

The exit guide plate closes at a specified interval after the stapled prints have started to feed out. Then the exit roller takes over the stack feed-out. The stack feed-out motor turns off when the pawl actuates the stack feed-out belt home position sensor [H].

When tray 1 is passing this area on its way back up to the upper exit, the exit guide safety switch [I] cuts power to the tray lift motor if the guide is opened too far. This prevents damage to the user's fingers if they are inside the lower exit when the tray is moving up.

4.8 PUNCH UNIT (OPTIONAL)

The punch unit punches holes in printed sheets, one by one. The punch unit is provided with a new punch mechanism to improve the accuracy of punching.

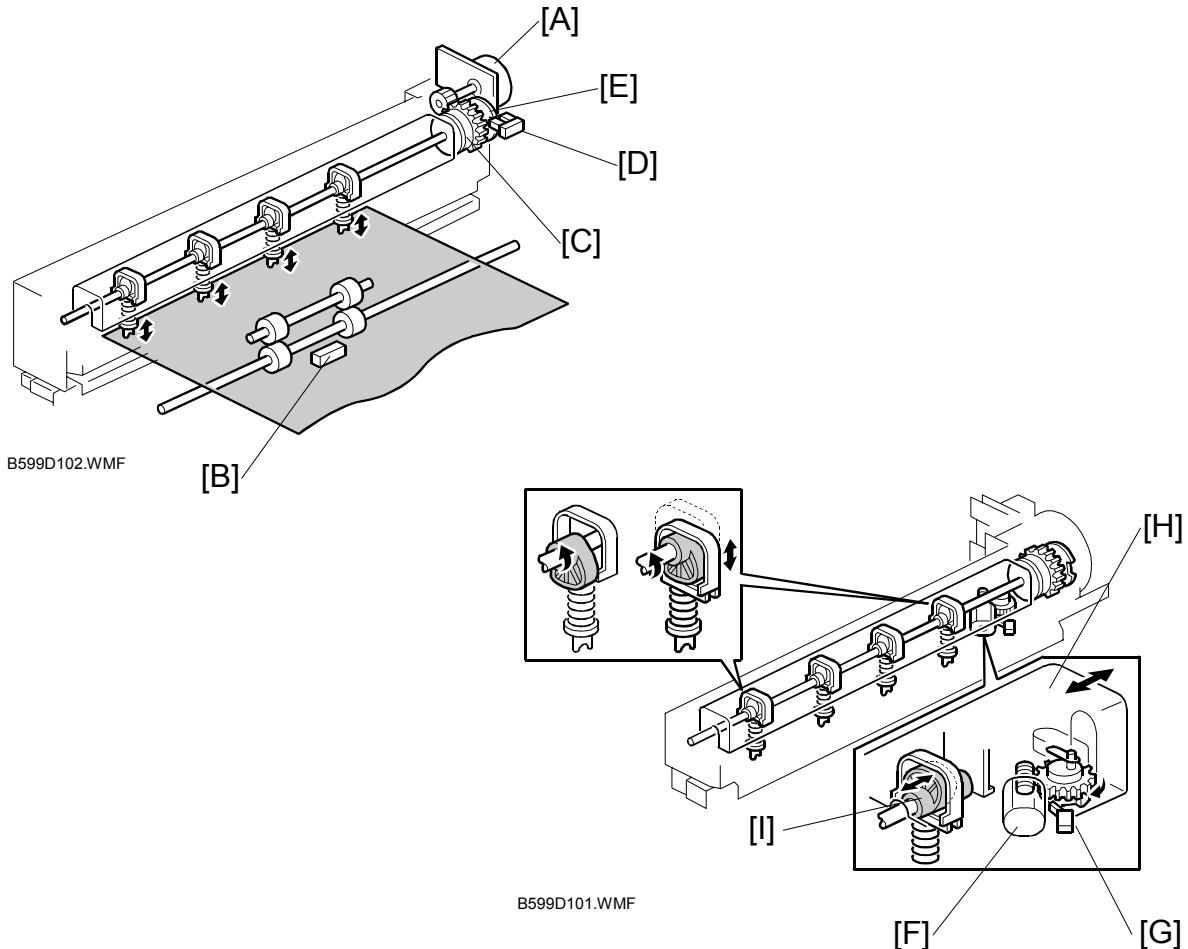

4.8.1 PUNCH DRIVE MECHANISM

The punch drive mechanism is driven by the punch motor [A]. Each sheet is positioned and punched by pressure from above. A certain time after the trailing edge of the paper passes through the finisher entrance sensor [B], the punch motor turns on and the paper stops. Then the punch clutch [C] turns on to make the punch holes.

The home position is detected by the punch HP sensor [D]. When the cut-out in the punch shaft disk [E] enters the punch HP sensor, the punch clutch turns off.

When the finisher has received the command that changes the number of punch holes, the punch hole motor [F] turns on until the disk changes the status of the punch hole switch [G] (until it switches on or off). This indicates that the cover [H] and the punch cam [I] have moved to one side or the other to change the number of holes.

4.8.2 PUNCH WASTE COLLECTION

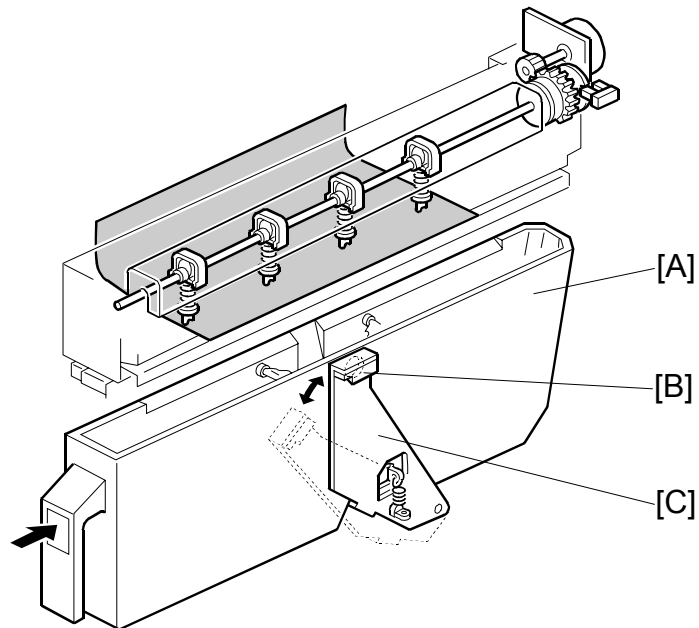

B599D153.WMF

Waste punchouts are collected in the punch waste hopper [A] below the punch unit inside the finisher.

When the top of the punchout waste in the hopper reaches and actuates the hopper sensor [B], a message will be displayed on the operation panel after the current job is completed.

This sensor also detects whether the punch waste hopper is installed. When the waste hopper is taken out, the arm [C] moves down and this will actuate the sensor and display a message in the operation panel. This message is the same as for the hopper full condition.